

2 System overview

2.1. Minisphere 100 AC/HAC (without fresh air)

The air-conditioning system Minisphere 100 AC / HAC and its main components are shown in figure 1.

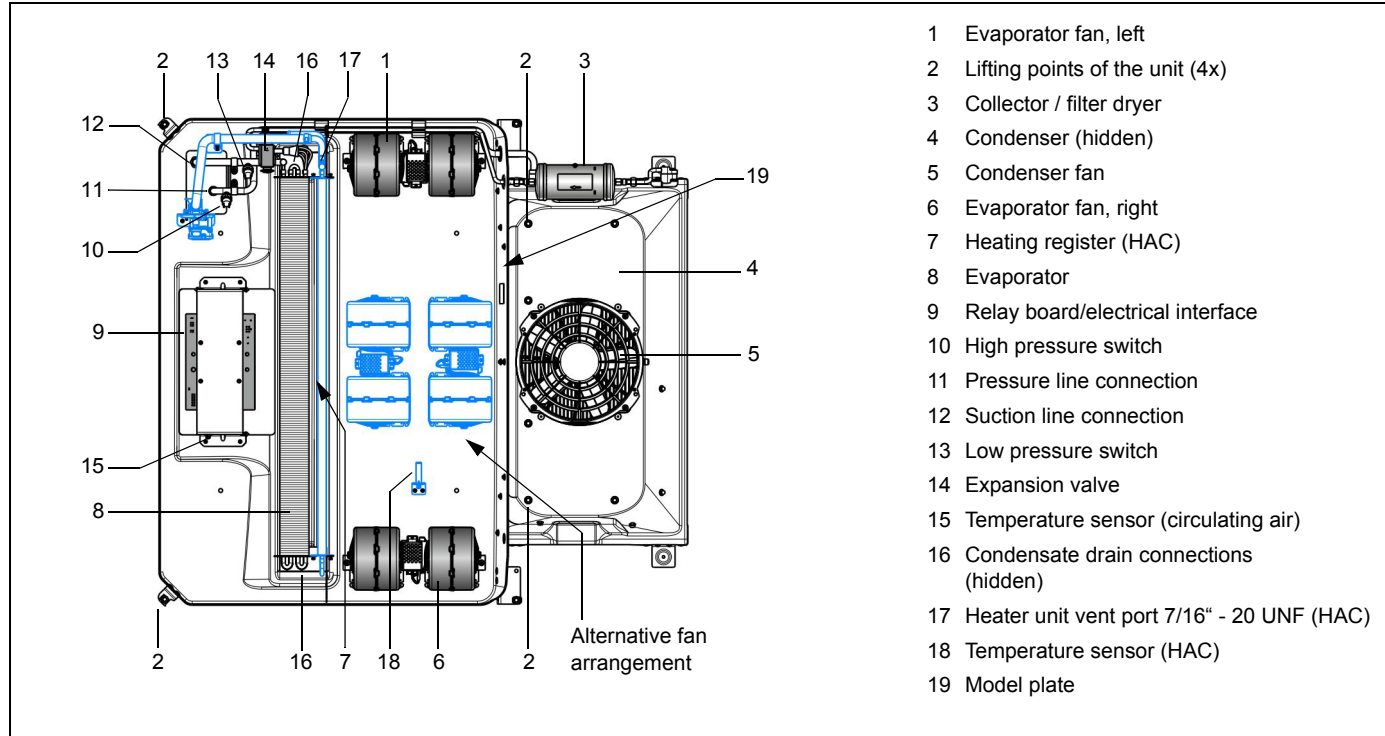

Fig. 1: Minisphere 100 AC/HAC

2.2. Minisphere 130 AC/HAC (without fresh air)

The air-conditioning system Minisphere 130 AC/HAC and its main components are shown in figure 2.

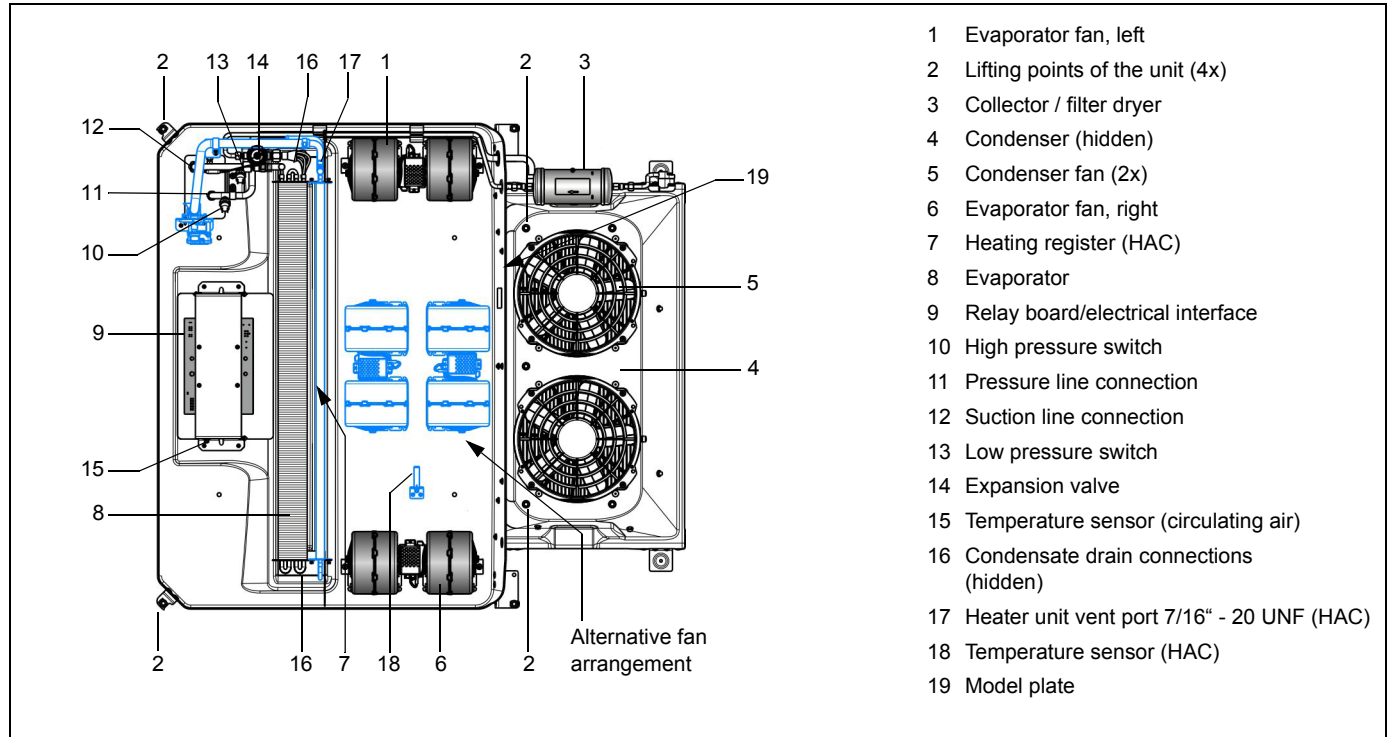

Fig. 2: Minisphere 130 AC/HAC

2.3. Minisphere 100/130 VAC/HVAC (with fresh air/roof heating)

The air-conditioning system Minisphere 100/130 VAC/HVAC and its main components are shown in figure 3.

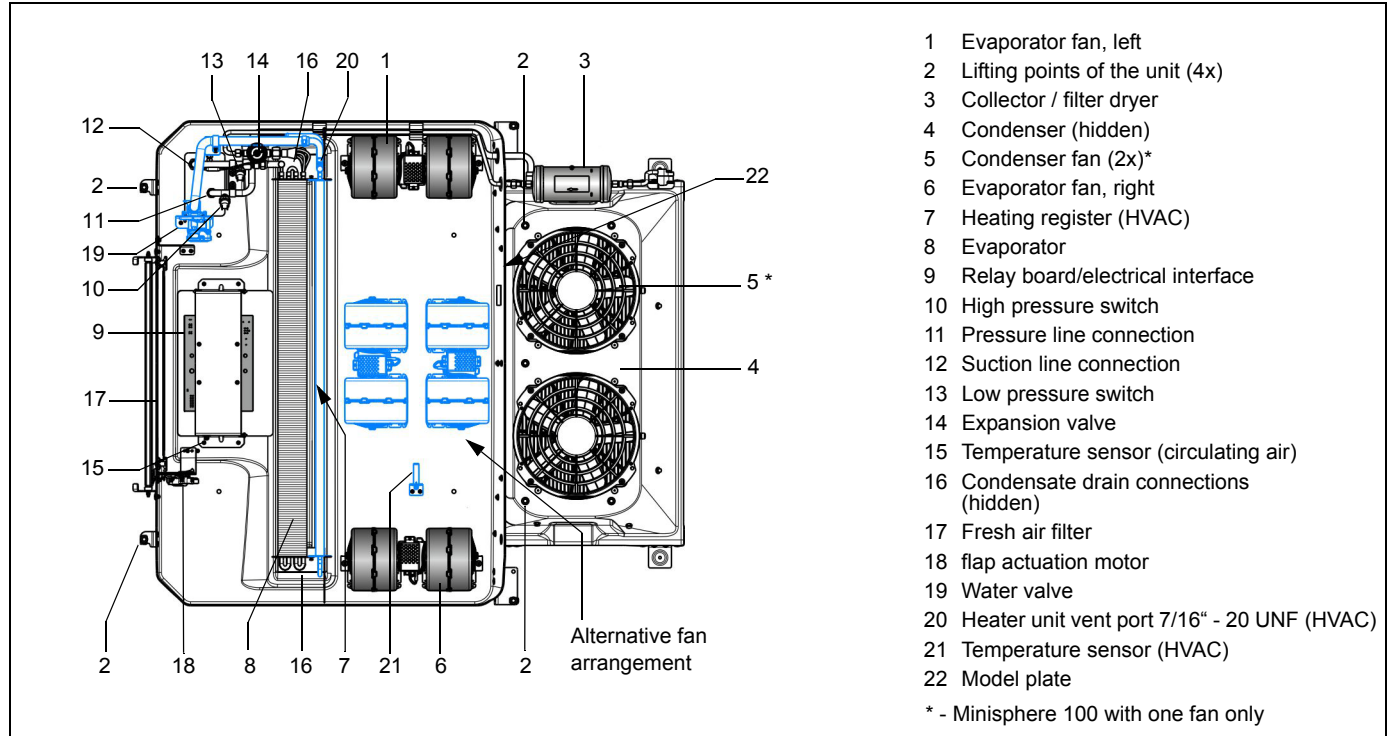

Fig. 3: Minisphere 100/130 VAC/HVAC